

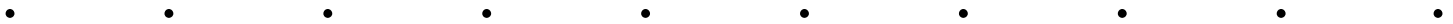

Thermo Technologies
5560 Sterrett Place, Suite 115
Columbia, MD 21044
Thermoteks.com
April 2004

Thermomax Solar Water Heater

Installation Manual



*Installation Procedure for Flatroof and
Ground*

Revision 7





Thermomax Solar Water Heater Installation

CAUTIONS

YOU MUST THOROUGHLY READ BASIC GUIDE FOR THERMOMAX TECHNICAL DETAILS & INSTALLATION MANUAL BEFORE COMMENCING SYSTEM INSTALLATION

1. The Thermomax tubes should under no circumstances be exposed to the sun for extended periods (maximum one day) if the system has not been filled. No load operation of the system will permanently damage Thermomax tubes.
2. The circulating pump should under no circumstances be switched off during a sunny day. This will create a high temperature and as a result, high pressure in the system. When not in use for extended periods, the circulating pump must be left switched on and a by-pass should divert the heat from the storage tank.
3. The contractor shall verify true south and shall orient the collector tubes facing true south. The collector tilt angle shall be nominally set at latitude but never less than 25° . At a lower inclination, the output of the collector will be reduced.
4. Unpack and install the collector tubes AFTER the manifold unit and pump has been installed and the piping has been connected.
5. Gloves and eye protection should be worn when handling the glass.
6. Avoid any sudden shock to the tubes.
7. Avoid scratching the glass collector tubes, as this will reduce their strength.
8. ALL LOCAL AUTHORITIES REGULATIONS AND RELEVANT STANDARDS SHOULD BE FOLLOWED.

Solar Collector Installation Procedure

Select suitable locations for Thermomax Solar arrays. It should face due true south with a tilt angle of location latitude. Collector sizes, distances between brackets, and corresponding tilt angle of the collector are given in the following pages.

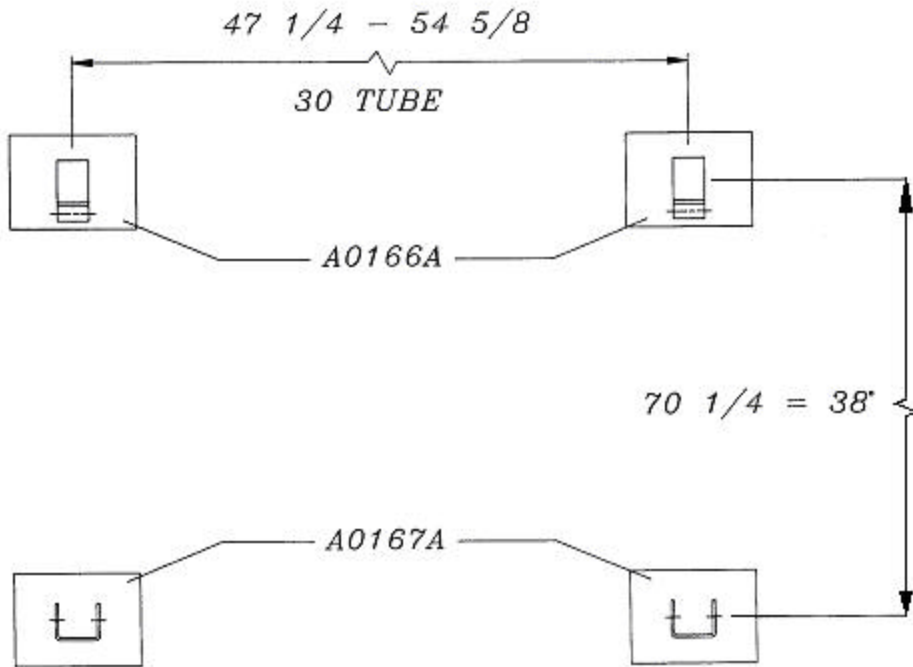

(1) Position and bolt front brackets (Pt. No. A0167A) and rear brackets (Pt. No. A0166A) to the cement block using coach screws (pt. No. A0168B). The cement block shall weight 100 lb. Minimum.

(2) Use lead plugs (pt. No. A0836A) in concrete blocks.

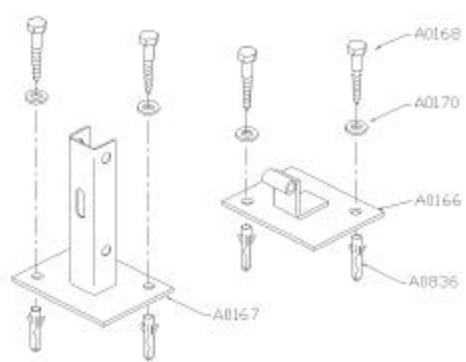

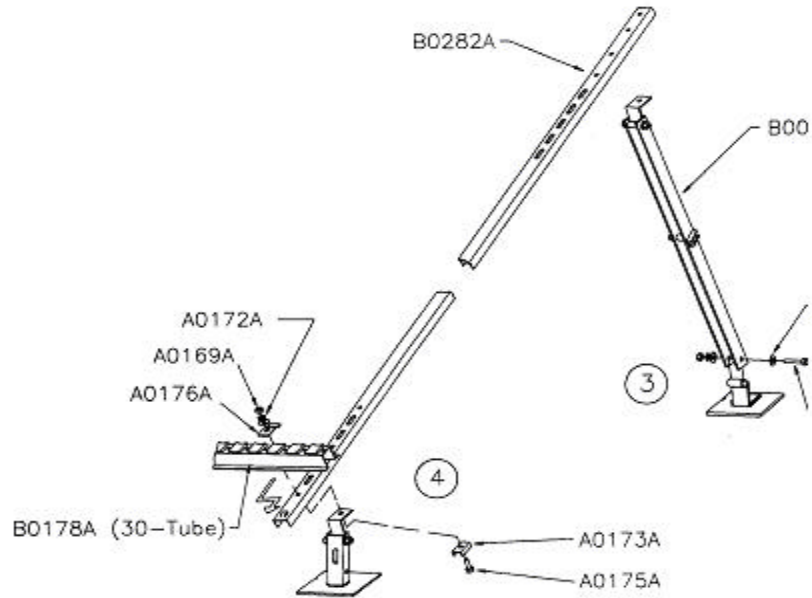

- (3) Fix rear struts (Pt. No. B0007C) to rear bracket.
- (4) Bolt the bottom support rail (pt. No B0178A) to side rail (Pt. No. B0282A) and the front brackets hinge (Pt. No. A0174A) using lower hole in side rail. Distances from side rails to ends of the support rail ends should be equal.

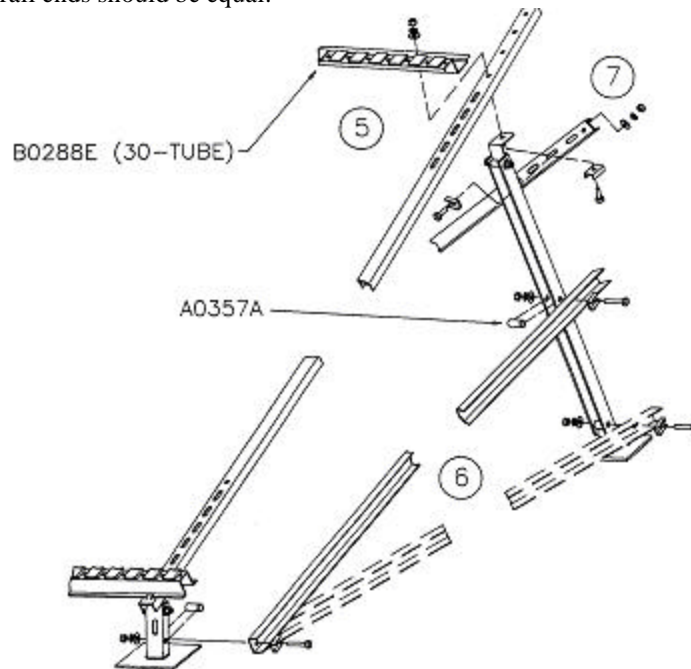

- (5) Bolt top support rail (pt. No. B0288E) through lower hole in top end of side rail to hinge plate on top of rear strut (Pt. No. B0007B). Distances from side rails to top support rail ends should be equal.
- (6) Locate and secure a universal brace (Part No. B0006B) using the single hole, to the front bracket. Secure slotted end of universal brace to rear strut in either position shown. Locate second universal brace on other side of frame.
- (7) Secure a third universal brace diagonally between rear struts and cut off any excess lengths.

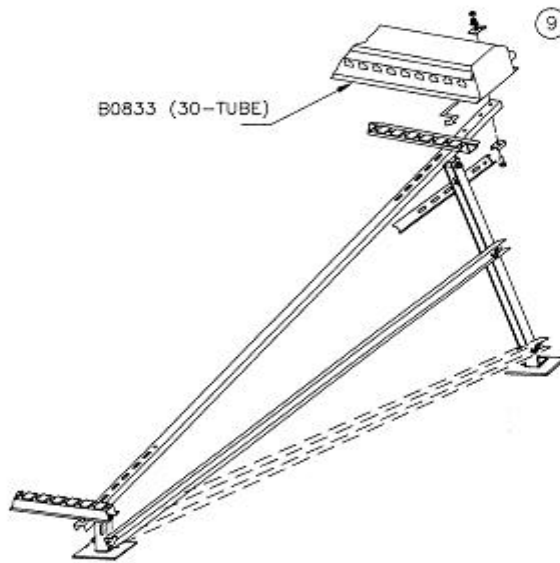

- (8) Tighten all nuts and bolts.
- (9) Locate manifold in top support rail lip and bolt as shown. Ensure the distance from the side rails to the manifold ends should be the same as the top support rail.

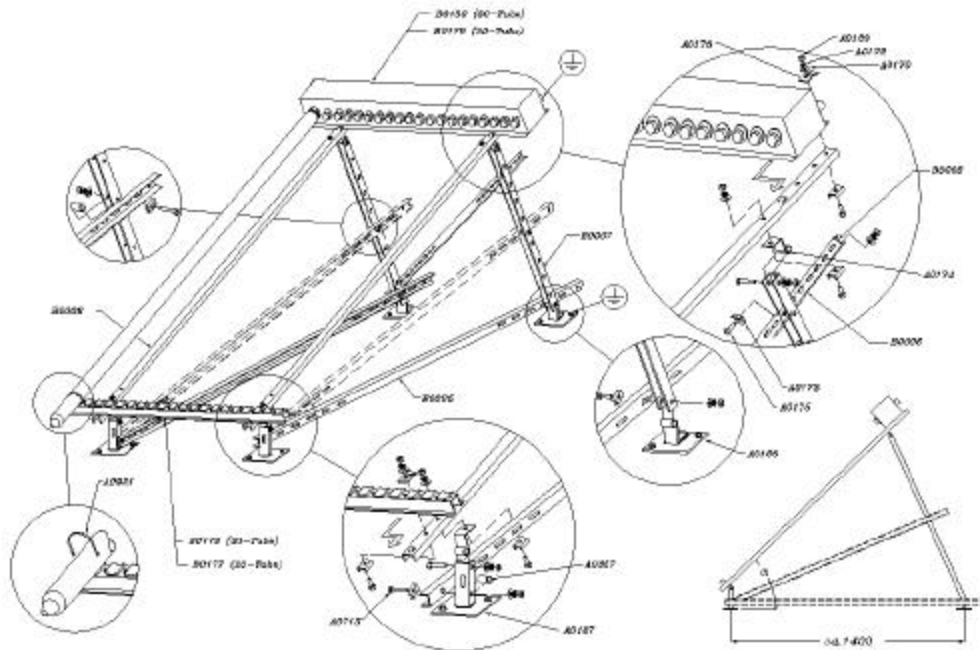

- (10) Locate manifold fittings to manifold inlet and outlet. Note that the air vent should be installed vertically.
- (11) Check all plumbing and piping between collector and hot water storage tank.
- (12) Switch on circulating pump.
- (13) Make sure there is no leak in piping system.
- (14) Check system pressure and flow rate.

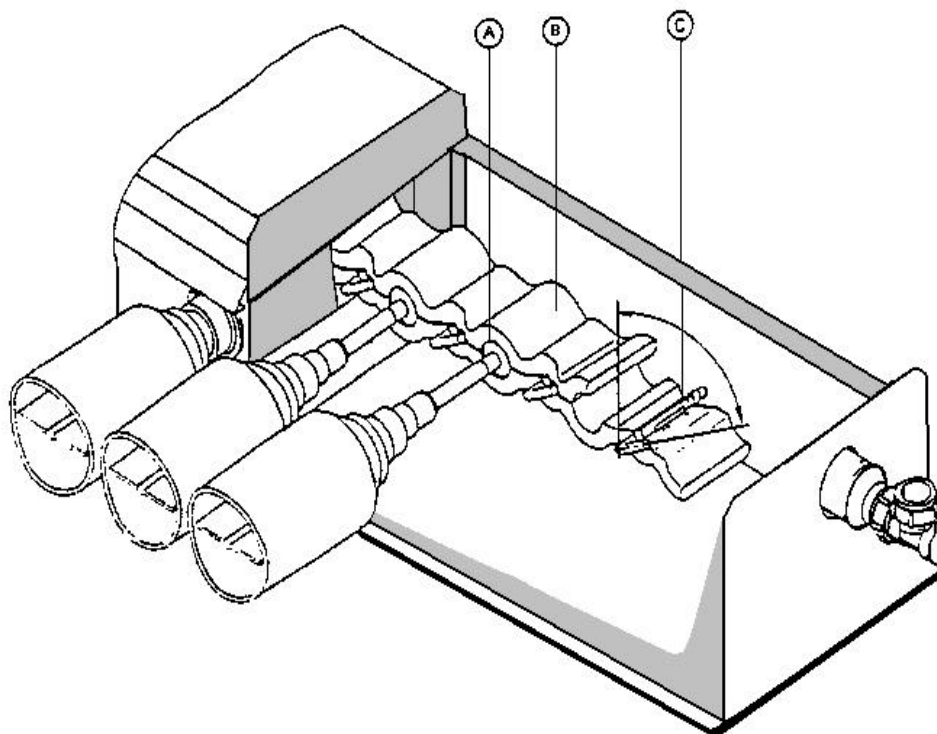

(15) Take-off manifold's lid and remove top layer of insulation from manifold.

(A) With the supplied Stainless steel tube (Key Lever) open the pocket in the manifold chamber "B" by turning the Key Level "C" through 90°. Unpack the first tube; insert condenser "A" gently through grommet in front of the manifold. Resting the tube body on the rubber pads of the top and bottom support rails, slide the condenser "A" into the open pocket. **ENSURE BLACK SURFACE OF ABSORBER FACES UPPERMOST AND TOWARDS THE SOUTH.**

(B) Make sure the tube condenser is exactly between the two copper blocks and sits evenly through hole in manifold chamber.

(C) Repeat stages (A) and (B) for all tubes. Secure tubes by turning the Key Lever to original position.

(D) Apply heat transfer paste (if needed) to the heat exchange blocks where the condenser makes contact. Replace top layer of insulation into manifold.

(16) Replace manifold's lid and secure with self-tapping screws.

(17) Make the final inspection on each tube.

(18) Set clips over tubes to both top and bottom support rails.

(19) Switch the pump to control system

The manifold flow and return connections are 3/4" copper pipes. Two compression couplings are included in each manifold system. These couplings are to be used. **Manifold inlet and outlet should not be soldered.**